

Part Number: PT47A-33130-XX

Kit Contents

Item #	Quantity Reqd.	Description
1	1	Lip Spoiler
2	1	Hardware Bag
3		

Hardware Bag Contents

Item #	Quantity Reqd.	Description
1	4	M6 Nuts
2		
3		

Additional Items Required For Installation

Item #	Quantity Reqd.	Description
1	1	Mylar Drill Template – Part No. PT47A-33130
2		
3		

Conflicts

Not Compatible with Ultra Luxury Package UL

General Applicability

All ES 350 vehicles

Recommended Sequence of Application

Item #	Accessory
1	
2	
3	

*Mandatory

Vehicle Service Parts (may be required for reassembly)

Item #	Quantity Reqd.	Description
1		
2		
3		



Recommended Tools

Personal & Vehicle Protection	Notes
Wrist and Belt Buckle Protectors	
Blankets	
Masking Tape	2" wide
Safety Goggles	
Special Tools	Notes
Non Intrusive IR Temperature Probe/Gun	
Installation Tools	Notes
Drill Motor	1/2"
Twist Drill Bits	9.0mm (23/64")
Drill Stops	9.0mm (23/64")
Deep Well Socket	10.0 mm
Swivel Socket	
Socket Extension	6", 12"
Ratchet	
Torque Wrench	0-100 lbf-in
Shop Vacuum	
Hole Deburring Tool	
Magnet With Flex Shaft	
Panel Fastener Removal Tool	
Nylon Trim Removal Tool	Toyota SST#: 00002-06001-01
Heat Gun	
Small Parts Bin	
Special Chemicals	Notes
Sealant	3M Ultra-Pro Body Sealant
Cleaner	3M™ Prep Solvent-70

Legend

	STOP: Damage to the vehicle may occur. Do not proceed until process has been complied with.
	OPERATOR SAFETY: Use caution to avoid risk of injury.
	CAUTION: A process that must be carefully observed in order to reduce the risk of damage to the accessory/vehicle and to ensure a quality installation.
	TOOLS & EQUIPMENT: Used in Figures calls out the specific tools and equipment recommended for this process.
	REVISION MARK: This mark highlights a change in installation with respect to previous issue.
	SAFETY TORQUE: This mark indicates that torque is related to safety.

Care must be taken when installing this accessory to ensure damage does not occur to the vehicle. The installation of this accessory should follow approved guidelines to ensure a quality installation.

These guidelines can be found in the "Accessory Installation Practices" document.

This document covers such items as:-

- Vehicle Protection (use of covers and blankets, cleaning chemicals, etc.).
- Safety (eye protection, rechecking torque procedure, etc.).
- Vehicle Disassembly/Reassembly (panel removal, part storage, etc.).
- Electrical Component Disassembly/Reassembly (battery disconnection, connector removal, etc.).

Please see your Lexus dealer for a copy of this document.

1. Remove the Trim Panel.

-  (a) Open the trunk and place blankets inside on the trunk floor and trunk opening (Fig. 1-1).

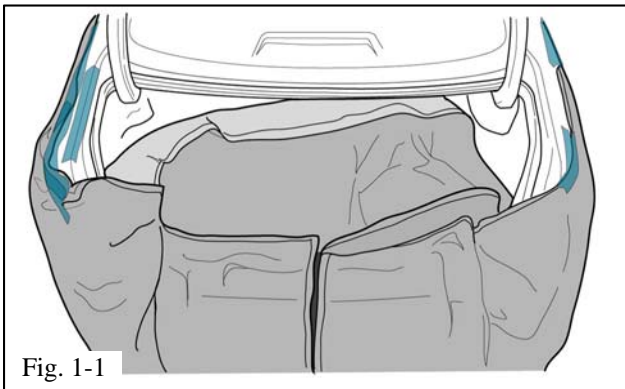

- (b) Remove the trim bezel for the emergency trunk release and then remove the handle for the release cable. The trim bezel can be unsnapped by hand (Fig. 1-2).

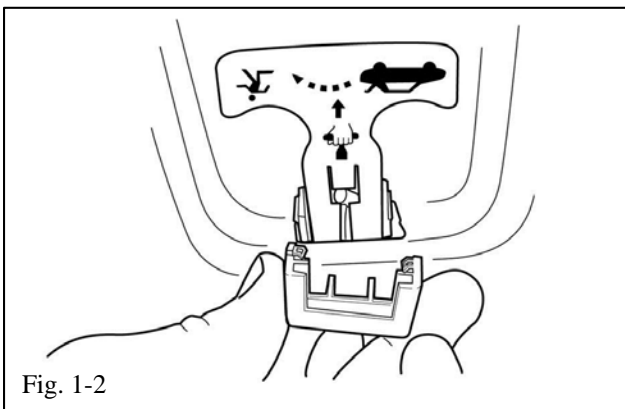

- (c) Remove the 11 black clips from the trunk inner panel and retain them for reinstallation (Fig. 1-3).

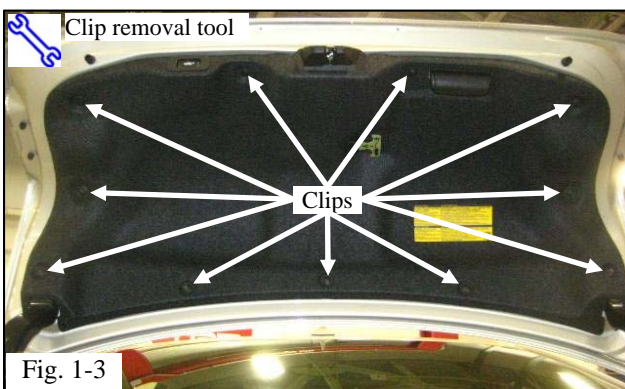

2. Drill the Mounting Holes.

+ (a) Eye protection must be worn during all drilling.

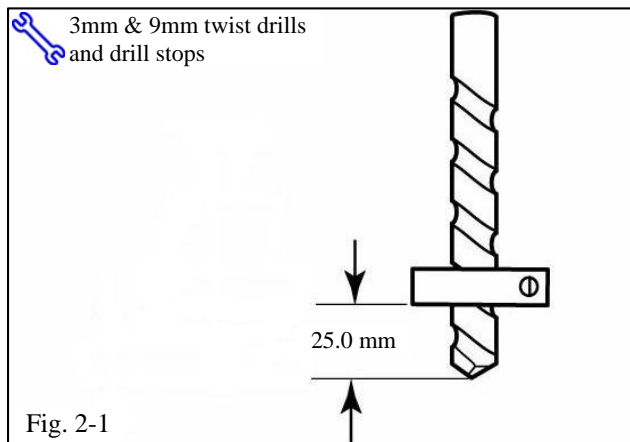

(b) Set all drill stops to 25.0 mm (Fig. 2-1).



(c) Apply masking tape to the trunk lid surface in the areas of the hole locations (Fig. 2-2).

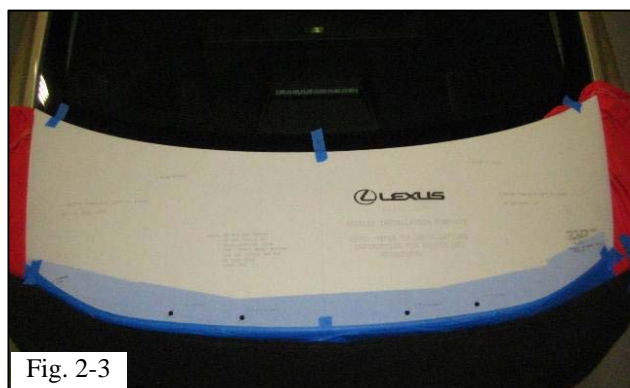

(d) Place the Mylar template on the vehicle.
Tape it in place, making sure the template is completely smooth and flat on trunk lid surface (Fig. 2-3).

(e) Use a center punch to punch the centers of the four (4) hole locations on the template.

! **NOTE:** The hole centers are punch marks within the segmented circles. The punch marks must be located and used for proper spoiler alignment.

(f) Remove the template. Make sure all four (4) punch marks are visible in the masking tape.

(g) Use a 3mm drill bit to drill a pilot hole at all four (4) hole locations.

STOP NOTE: Make sure the holes are not allowed to drift from the punched center locations.

(h) Use a 9mm drill bit to drill the final hole at all four (4) hole locations.

(i) Use a deburring tool to carefully deburr the four (4) drilled holes (Fig. 2-4).

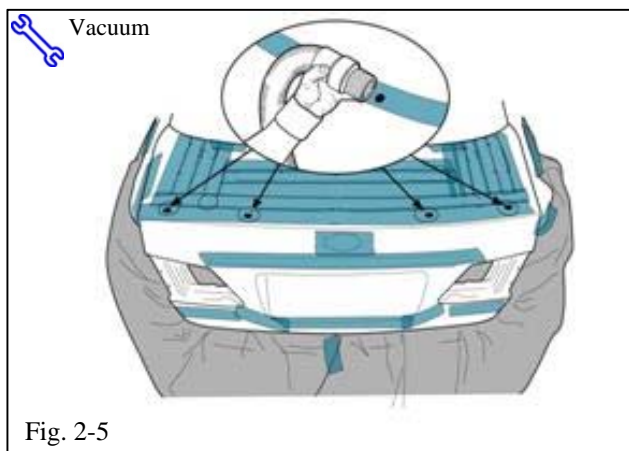
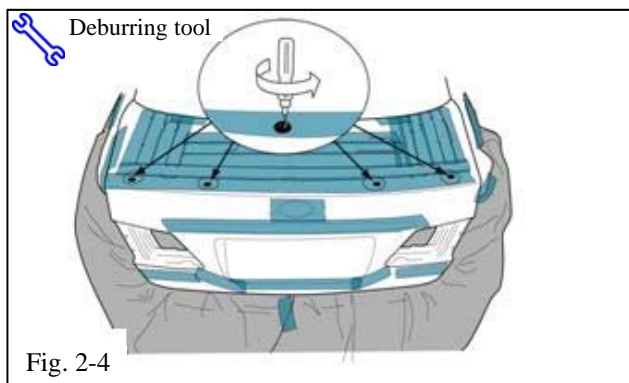

(j) Vacuum the surface of the trunk lid and the surrounding drilled areas, then remove the masking tape (Fig. 2-5).

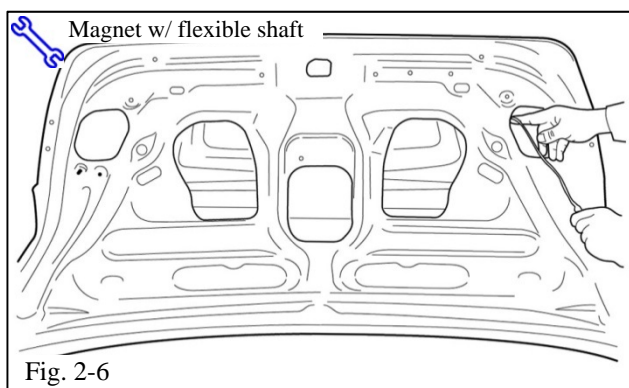

(k) Open the trunk lid and use a magnet with a flexible shaft to remove any remaining metal chips from the drilling process (Fig. 2-6).

3. Prepare to Attach the Spoiler.

- (a) The trunk lid where the spoiler attaches must be cleaned with 3MTM Prep Solvent-70 and a lint free cloth.
- (b) After cleaning, carefully apply 3M Ultra-Pro Body Sealant to all drilled hole edges (Fig. 3-1).
- (c) The trunk and spoiler should be a minimum of 60° F for proper set-up of the adhesive tape. Use a hot air blower to heat the surface if the temperature is below 60° F. The adhesive tape on the spoiler must have full contact between spoiler and trunk lid for proper sealing to the trunk lid.

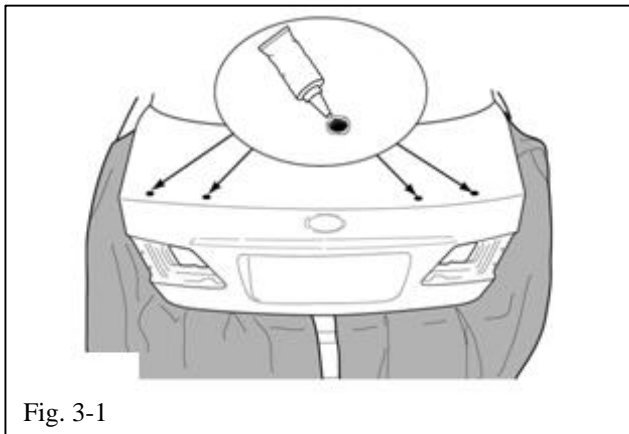

Fig. 3-1

4. Attach the Spoiler to the Trunk Lid.

- (a) Fold back and tape the plastic pull tabs to the outside surface of the spoiler. Be careful not to touch or allow any contaminants to come into contact with the adhesive tape (Fig. 4-1).

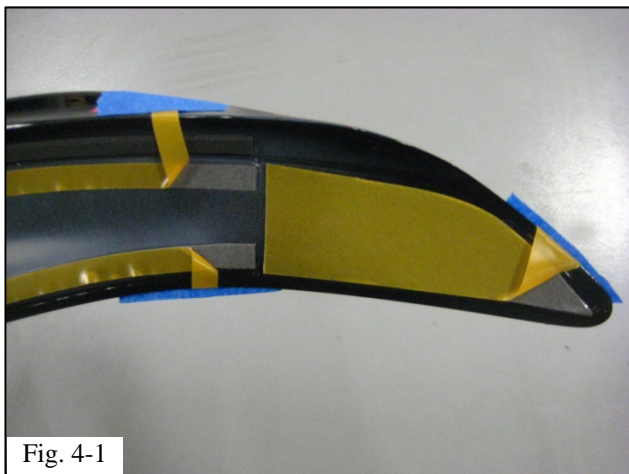



Fig. 4-1



- (b) Completely remove the plastic liner from the center square adhesive tape pad (Fig. 4-2).



-  (c) Lightly place the spoiler on the trunk lid (Fig. 4-3).

- (d) Center the spoiler on the trunk lid so that the distance between the spoiler edge and the trunk lid on each side is ± 2 mm at the ends.

- (e) Remove the rear tape tabs.

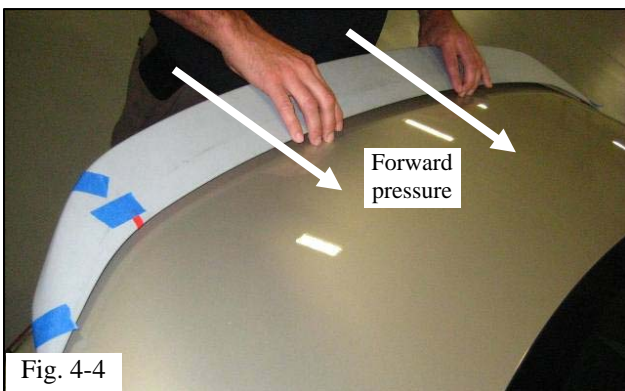

- (f) Apply forward pressure on the spoiler to ensure tape adhesion (Fig. 4-4).

- (g) Remove the top tape tabs.

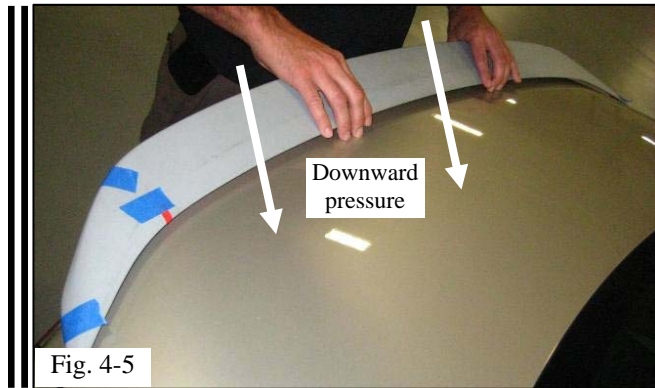

(h) Apply downward pressure on the spoiler (Fig. 4-5).

- ⚠ (i) Open the trunk lid and install the four (4) M6 nuts to the studs. Tighten all four fasteners to 5.4 N·m (48 in·lbf).

⚠ **Torque: 5.4 N·m (48 in·lbf)**

(j) Push down on the spoiler again to fully seat the spoiler on the trunk lid.

5. Reassemble the Vehicle.

- (a) Reinstall all removed panels and parts. Be sure that all the panel clips are engaged.
- ⚠ (b) Check that no drill shavings/chips are in the vehicle trunk area or on the rear bumper.

Checklist - these points **MUST** be checked to ensure a quality installation.

<u>Check:</u>	<u>Look For:</u>
<p><u>Accessory Function Checks</u></p> <ul style="list-style-type: none"> <input type="checkbox"/> Check for spoiler alignment <input type="checkbox"/> Check for full tape adhesion <input type="checkbox"/> <input type="checkbox"/> 	<p>Centered from side to side (+/- 2 mm)</p> <p>Full adhesion with no gaps</p>
<p><u>Vehicle Function Checks</u></p> <ul style="list-style-type: none"> <input type="checkbox"/> Verify trunk lid operation <input type="checkbox"/> Verify Emergency Trunk Release Handle operation <input type="checkbox"/> 	<p>When opened, the trunk lid should initially pop up slightly and remain in the fully raised position when opened fully</p> <p>Emergency Trunk Release Handle operates correctly. (With the trunk lid in the open position, trip the trunk lock closed using a nylon pry tool. Pull the emergency trunk release handle and verify the trunk lock has opened.)</p>
<p><u>Vehicle Appearance Check</u></p> <ul style="list-style-type: none"> <input type="checkbox"/> After accessory installation and removal of protective cover(s), perform a visual inspection. 	<p>Ensure no damage (including scuffs and scratches) was caused during the installation process. (For PPO installations, refer to TMS Accessory Quality Shipping Standard.)</p>