

**Part Number: PT767-76190**

**Kit Contents**

Item #	Quantity Reqd.	Description
1	2	Roof Rack Crossbar Assembly
2	1	Hardware Bag
3	1	Crossbar Covers (qty 4)

**Hardware Bag Contents**

Item #	Quantity Reqd.	Description
1	1	Torque Wrench
2	1	Owners Guide

**Additional Items Required For Installation**

Item #	Quantity Reqd.	Description
1		
2		
3		

**Conflicts**

None
------

**Recommended Tools**

<b>Personal &amp; Vehicle Protection</b>	<b>Notes</b>
Safety Glasses	
Safety Gloves	
Vehicle Protection	Blanket
Wrist & Belt Buckle Protection	
<b>Special Tools</b>	<b>Notes</b>
<b>Installation Tools</b>	<b>Notes</b>
3/8" drive socket wrench	
T27 Torx bit w/3/8" adaptor	
13mm socket	
<b>Special Chemicals</b>	<b>Notes</b>

**General Applicability**

MY19 and newer UX,UXh Vehicles
--------------------------------

**Recommended Sequence of Application**

Item #	Accessory
1	
2	
3	

\*Mandatory

**Vehicle Service Parts** (may be required for reassembly)

Item #	Quantity Reqd.	Description
1		
2		
3		

**Legend**

 **STOP:** Damage to the vehicle may occur. Do not proceed until process has been complied with.

 **OPERATOR SAFETY:** Use caution to avoid risk of injury.

 **CAUTION:** A process that must be carefully observed in order to reduce the risk of damage to the accessory/vehicle and to ensure a quality installation.

 **TOOLS & EQUIPMENT:** Used in Figures calls out the specific tools and equipment recommended for this process.

 **REVISION MARK:** This mark highlights a change in installation with respect to previous issue.

 **SAFETY TORQUE:** This mark indicates that torque is related to safety.

Care must be taken when installing this accessory to ensure damage does not occur to the vehicle. The installation of this accessory should follow approved guidelines to ensure a quality installation.

These guidelines can be found in the "Accessory Installation Practices" document.

This document covers such items as:

- Vehicle Protection (use of covers and blankets, cleaning chemicals, etc.).
- Safety (eye protection, rechecking torque procedure, etc.).
- Vehicle Disassembly/Reassembly (panel removal, part storage, etc.).
- Electrical Component Disassembly/Reassembly (battery disconnection, connector removal, etc.).

Please see your Toyota dealer for a copy of this document.

### 1. Install Front Crossbar.

**NOTE:** Be careful during installation to prevent scratching of roofs rails and vehicle roof. Cover vehicle roof with blanket if necessary.

(a) The right hand front crossbar is identified as "RHF" located on the clamp/support of the cross bar (Fig. 1-1).

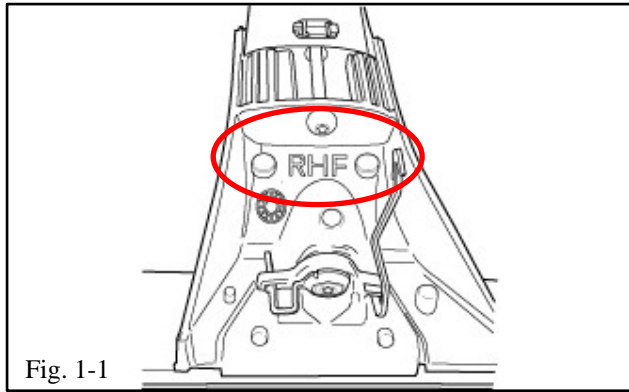

Fig. 1-1

(b) Align the pins of the "RHF" (right hand front) side clamp/support (passenger side) to the second set of roof rail mounting holes from the front of vehicle (Fig. 1-2).

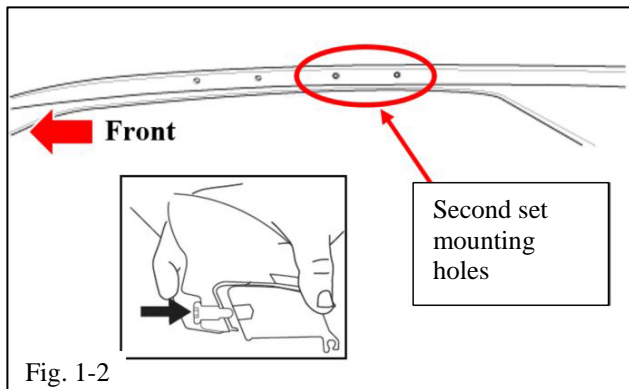
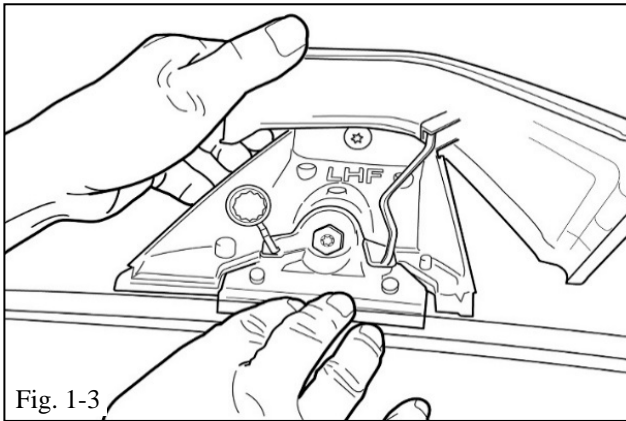
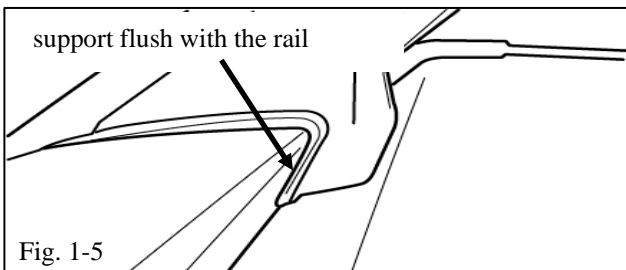
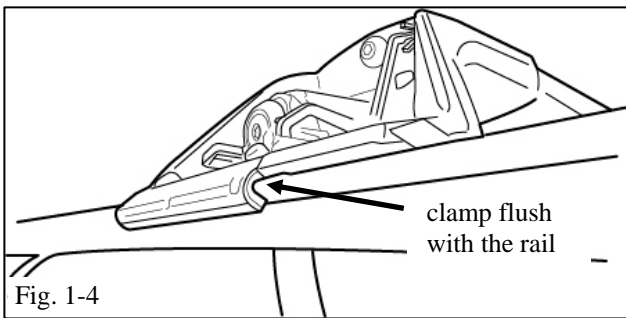

Fig. 1-2



(c) Adjust by sliding the LHF side clamp/support (driver side) inward or outward to align clamp/support pins with the opposite roof rail mounting holes for snug fit (Fig. 1-3 & 1-4).



**NOTE:** Ensure the pins are in rails holes. Ensure pads located underneath the supports are flush to the rail for proper assembly (Fig.1-5).

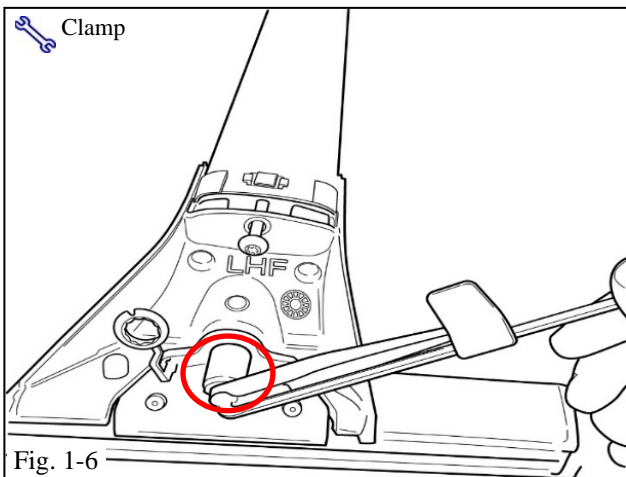

(d) While holding the clamp with the pins aligned into rail holes, use the supplied torque wrench, torque each main attaching screw to 9 N-m (71 in-lbs.) (Fig. 1-6).

**Torque: 9 N-m (71 in-lbs.)**

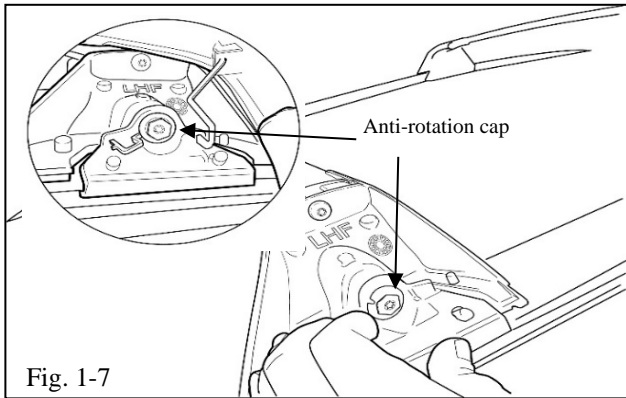

⚠ (e) Place the anti-rotation cap over the attachment screw (Fig. 1-7).

⚠ (f) Tighten only the LHF cross bar attachment screw.

(1) **For PPO installation:** Torque the screw to 1 N-m (9 in-lbs.).

**Torque: 1 N-m (9 in-lbs.)**

(2) **For DIO installation:** Tighten the screw until it bottoms out, plus one turn (Fig. 1-8).

⚠ **NOTE:** Do not loosen or tighten RHF cross bar attachment screw.

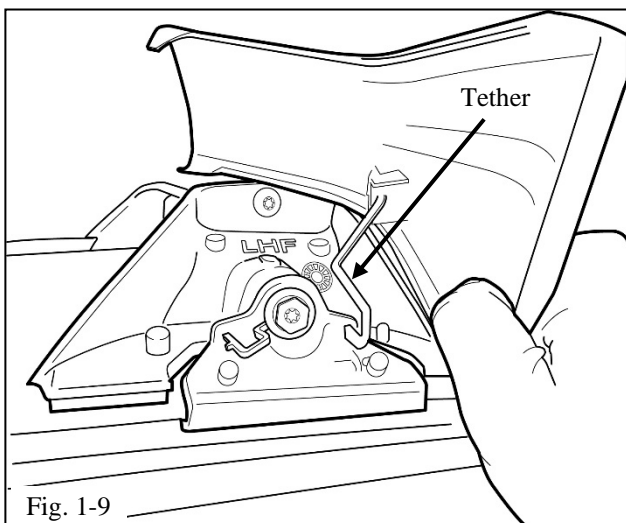
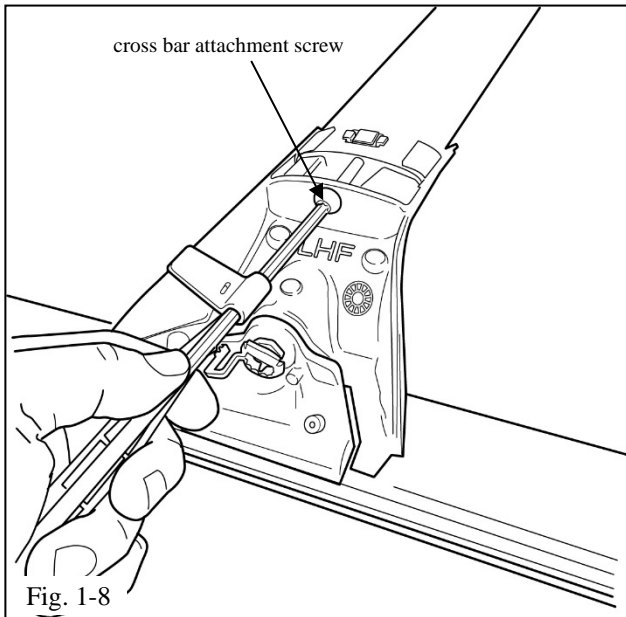

(g) Attach the tether to the cover (Fig 1-9).

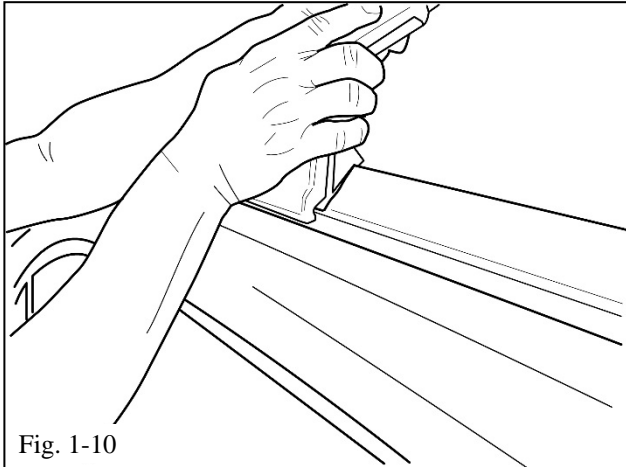

- (h) Slide top of the cover around the bar and snap in the tabs at the base of the cover onto clamp/support (Fig 1-10).

## 2. Install Rear Crossbar.

- (a) Repeat steps 1(a) through 1(g) for the rear crossbar.

## 3. Installation Instructions Placement

-  (a) Place owner's guide and torque tool inside bag. Then place the bag with contents into the vehicle's glove box.

Checklist - these points **MUST** be checked to ensure a quality installation.

<u>Check:</u>	<u>Look For:</u>
<p><u>Accessory Function Checks</u></p> <ul style="list-style-type: none"><li><input type="checkbox"/> Ensure crossbars are secure and in correct position.</li><li><input type="checkbox"/> Crossbar Installation Instructions/torque tool.</li><li><input type="checkbox"/> Crossbar gaps to rail</li></ul>	<p>Crossbars should have snug fit to rail.</p> <p>Owner's Guide and torque tool are inside glove box.</p> <p>Protective pads should not have gap to rail.</p>
<p><u>Vehicle Function Checks</u></p> <ul style="list-style-type: none"><li><input type="checkbox"/></li><li><input type="checkbox"/></li></ul>	
<p><u>Vehicle Appearance Check</u></p> <ul style="list-style-type: none"><li><input type="checkbox"/> After accessory installation and removal of protective cover(s), perform a visual inspection.</li></ul>	<p>Ensure no damage (including scuffs and scratches) was caused during the installation process.</p> <p>(For PPO installations, refer to TMS Accessory Quality Shipping Standard.)</p>