

**Part Number: PT347-60031**

**Kit Contents**

Item #	Quantity Reqd.	Description
1	1	Convenience Net
2	1	Installation Instructions
3	1	Hardware Bag

**Hardware Bag Contents**

Item #	Quantity Reqd.	Description
1	2	T-Anchors
2	2	Weld Studs

**Additional Items Required For Installation**

Item #	Quantity Reqd.	Description
1		
2		

**Conflicts**

--

**Recommended Tools**

<b>Personal &amp; Vehicle Protection</b>	<b>Notes</b>
Vehicle Protection	Blanket Masking Tape 1"
<b>Special Tools</b>	<b>Notes</b>
None	
<b>Installation Tools</b>	<b>Notes</b>
Drill Motor	
Drill Bit	6.35mm ( 1/4")
Drill Stop	Set to 5mm
Center punch	Spring Loaded
Shop Vacuum	
Panel Clip Removal Tool	e.g. Toyota SST P/N:- 00002-06002-01
<b>Special Chemicals</b>	<b>Notes</b>
None	

**General Applicability**

--

**Recommended Sequence of Application**

Item #	Accessory
1	
2	





\*Mandatory

**NOTE:** Part number of this accessory may not be the same as the part number shown.

**Vehicle Service Parts** (may be required for reassembly)

Item #	Quantity Reqd.	Description
1		
2		
3		

**Legend**

	<b>STOP:</b> Damage to the vehicle may occur. Do not proceed until process has been complied with.
	<b>OPERATOR SAFETY:</b> Use caution to avoid risk of injury.
	<b>CAUTION:</b> A process that must be carefully observed in order to reduce the risk of damage to the accessory/vehicle and to ensure a quality installation.
	<b>TOOLS &amp; EQUIPMENT:</b> Used in Figures calls out the specific tools and equipment recommended for this process.

Care must be taken when installing this accessory to ensure damage does not occur to the vehicle. The installation of this accessory should follow approved guidelines to ensure a quality installation.

These guidelines can be found in the "Accessory Installation Practices" document.

This document covers such items as:-

- Vehicle Protection (use of covers and blankets, cleaning chemicals, etc.).
- Safety (eye protection, rechecking torque procedure, etc.).
- Vehicle Disassembly/Reassembly (panel removal, part storage, etc.).
- Electrical Component Disassembly/Reassembly (battery disconnection, connector removal, etc.).

Please see your Lexus dealer for a copy of this document.

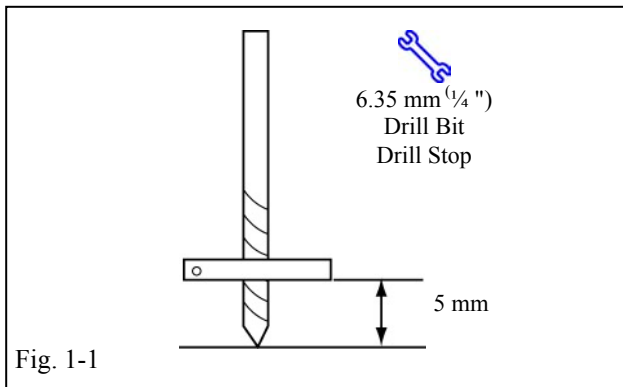

**1. Install Hardware.**

(a) Open rear hatch door.



Apply vehicle protection (blanket) to rear sill and fascia.



(b) Set drill stop to 5mm (Fig. 1-1).

(c) Apply strip of masking tape as protection to right side lower rear trim panel (Fig. 1-2).

(d) Mark drilling location as shown.

(1) 145mm (5.7") down from top of lower trim panel.

(2) 38mm (1.5") in from rear edge of lower trim panel.

(e) Center punch the panel at drilling location.

(f) Drill a 6.35mm (1/4") hole into the plastic trim panel as shown (Fig. 1-2).

(1) Remove masking tape from panel.

(2) Vacuum any remaining drill chips from the vehicle interior.



(g) Using the panel clip removal tool, carefully pry back the interior panel (Fig. 1-3).

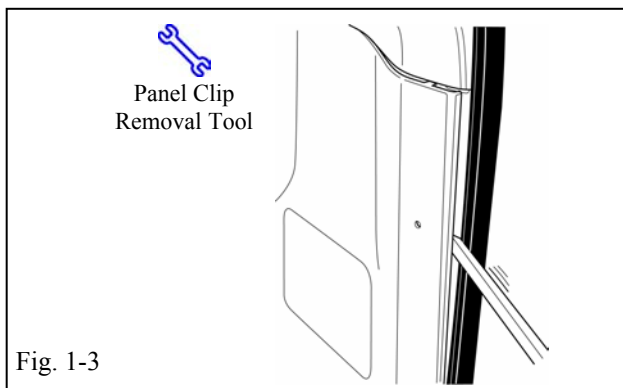
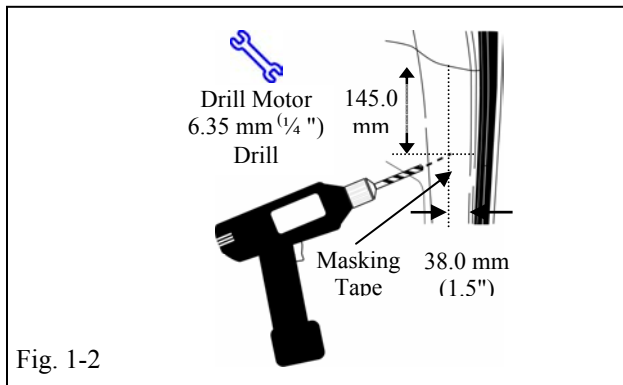



- (h) Insert the weld stud into hole through the back of the panel as shown (Fig. 1-4).
- (i) Attach and tighten the T-anchor (Fig. 1-5).
  - (1) Tighten T-anchor, and ensure it is vertical.
- (j) Securely reposition the panel.
- (k) Repeat steps 1. (a) through 1. (k) for the other side of the vehicle.

**2. Attach Cargo Net.**

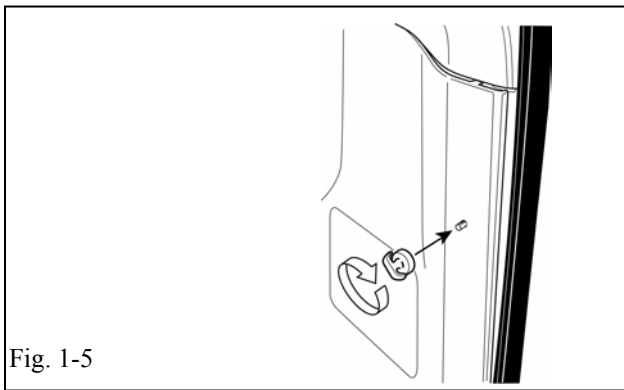

- ⚠ (a) Attach the cargo net to the T-anchors at the top and the D-rings at the bottom as shown (Fig. 2-1).
- ⚠ (1) Make sure handle on net faces toward the outside of the vehicle.
- (b) Repeat step 2. (a) for the other side of the vehicle.
- ⚠ (c) Confirm completed assembly.

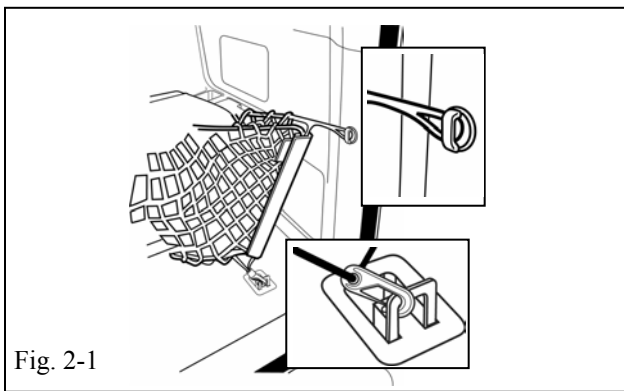

Checklist - these points **MUST** be checked to ensure a quality installation.

Check:

Look For:

Accessory Function Checks

- Confirm that the net is attached properly to the anchor points in the vehicle.

Make sure hooks are attached to floor D-rings and the loops are attached to the T-anchors at the top.

Vehicle Function Checks

- Confirm that the plastic trim panel is securely fastened after the T-anchor weld stud attachment.

Make sure plastic trim panel is repositioned.